

## Helicoil Holes

When using helicoils in parts, it may be preferable to show the threaded insert as a double-check for interference issues. There may be another screw hole or other part feature that may intersect the helicoil.

Some companies prefer to use a separate Helicoil part in an assembly to represent threaded inserts. This permits an accurate Bill of Materials (BOM) report for ordering parts.

Another method would be to add a second COSMETIC THREAD to the existing threaded hole. When using pattern tables for multiple holes, the additional cosmetic thread would be either added and grouped with the original threaded hole or be added as a related pattern. (see Tip - Patterned holes)

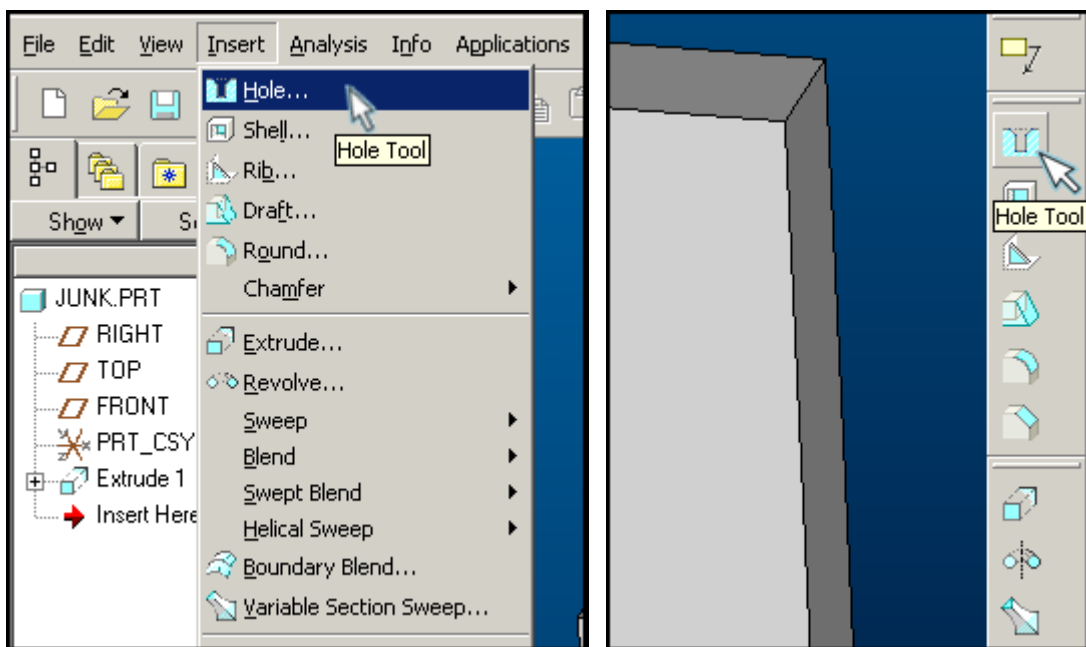

Insert a threaded hole using either the Insert -> Hole or the right tool bar.

-----

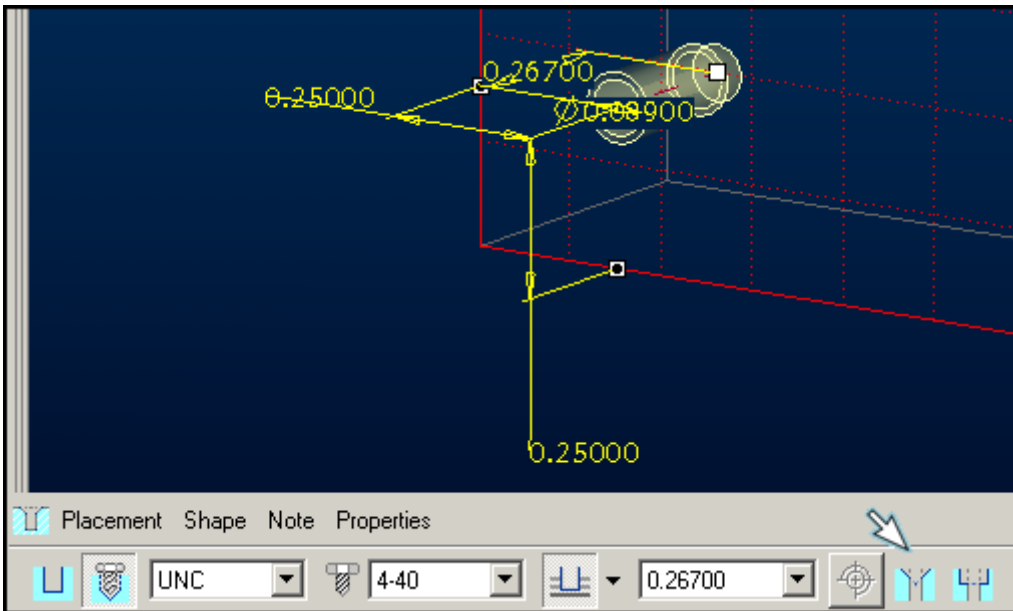

Select the Primary surface for hole placement and drag the handles to define the Secondary References for locating the hole. Select the Threaded hole symbol and thread type and size. You may also wish to turn off the default counter-sink icon.

-----

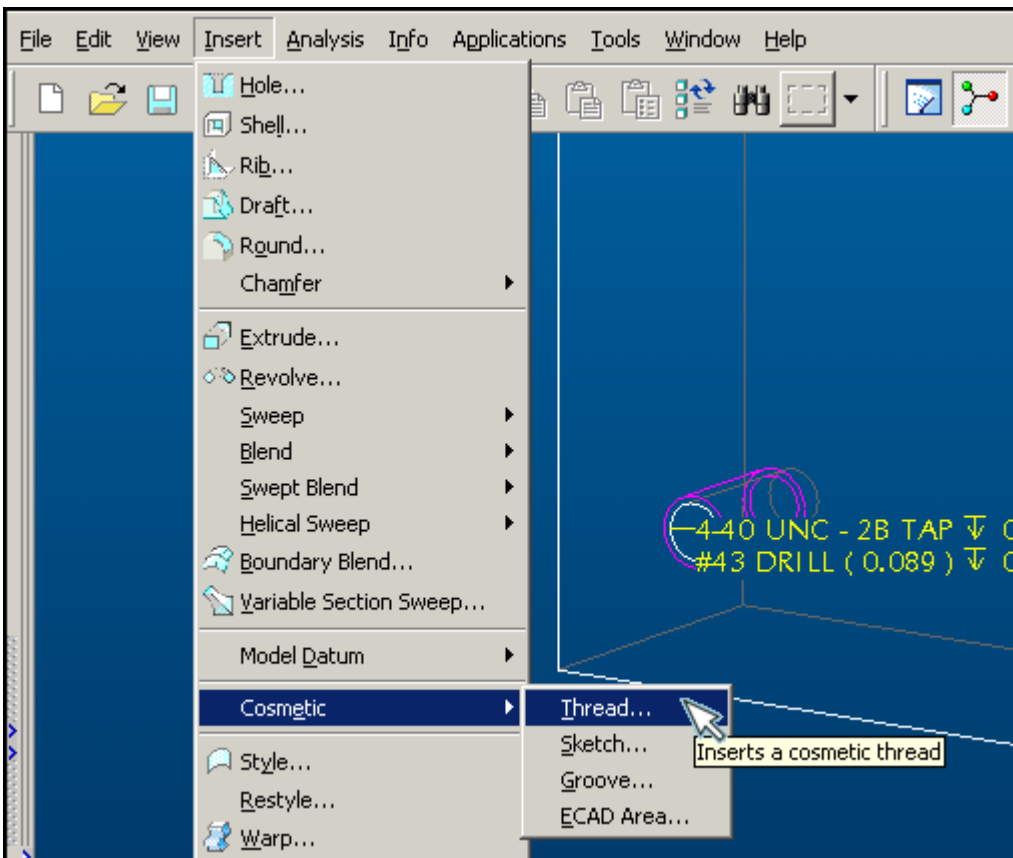

Insert the Helicoil thread by selecting Insert -> Cosmetic -> Thread

-----

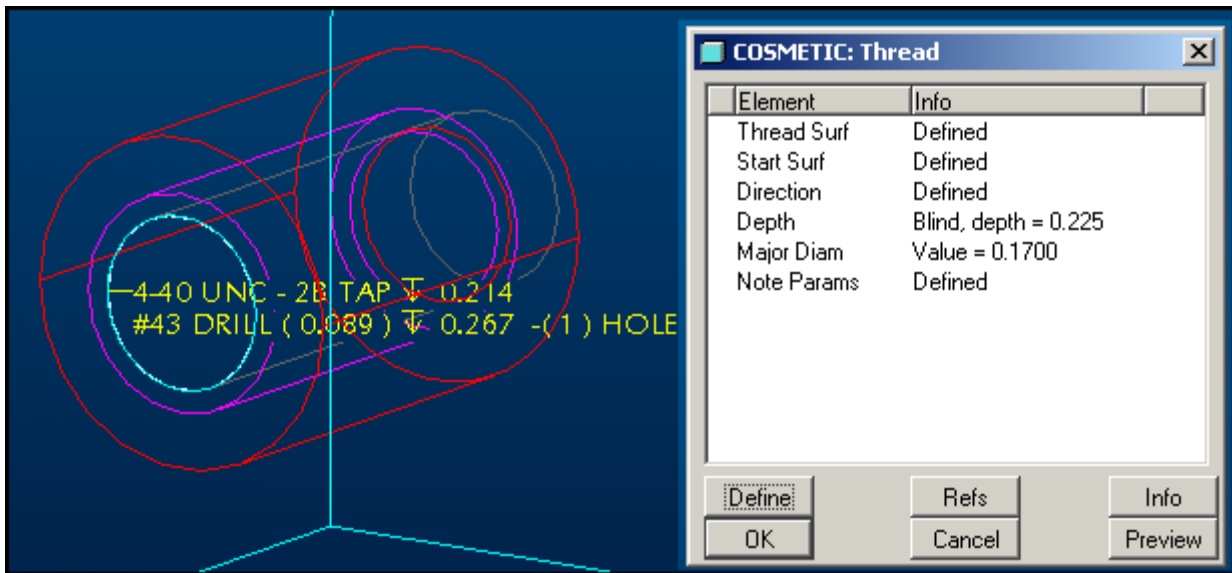

Select the:

Thread Surface (surface of the original hole)

Start Surface (flat surface the original hole was placed on)

Direction

Depth - Blind (Helicoils are sized by 1xThread Dia, 1-1/2xThread Dia, 2xThread Dia, etc)

Major Diam (I usually use the Max Countersink Diameter - See Helicoil Table)

Note Param -> Done/Return

[OK]

-----

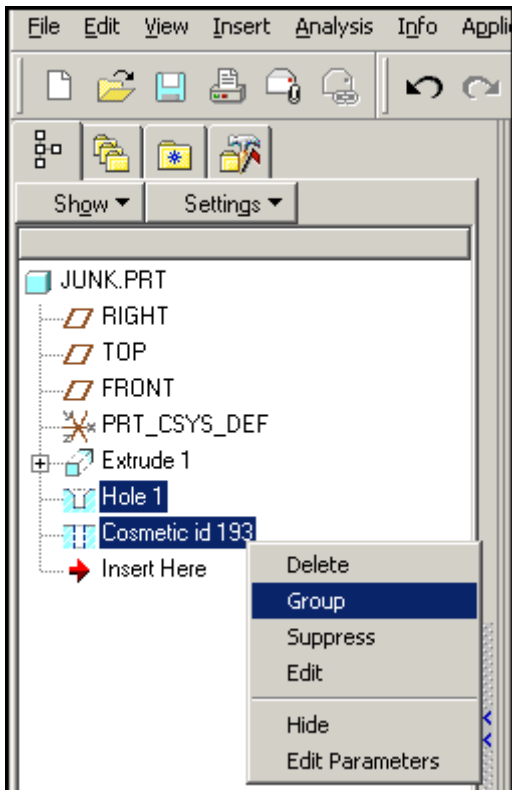

To create a pattern, Group the Hole and the Cosmetic Thread.

-----

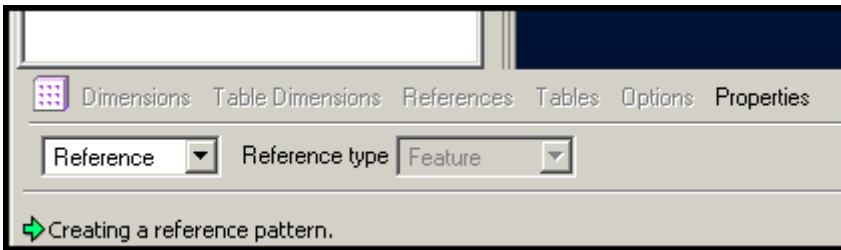

Or create a second pattern for the cosmetic thread using the Reference option. This will reference the original pattern for the threaded hole. Any modifications to the threaded hole pattern will be reflected by the referenced pattern when the model is Regenerated.

## CSink / CBores Clearance Holes

There are a couple different methods for creating Countersink / CounterBore clearance holes.  
 1 - Insert a threaded clearance hole

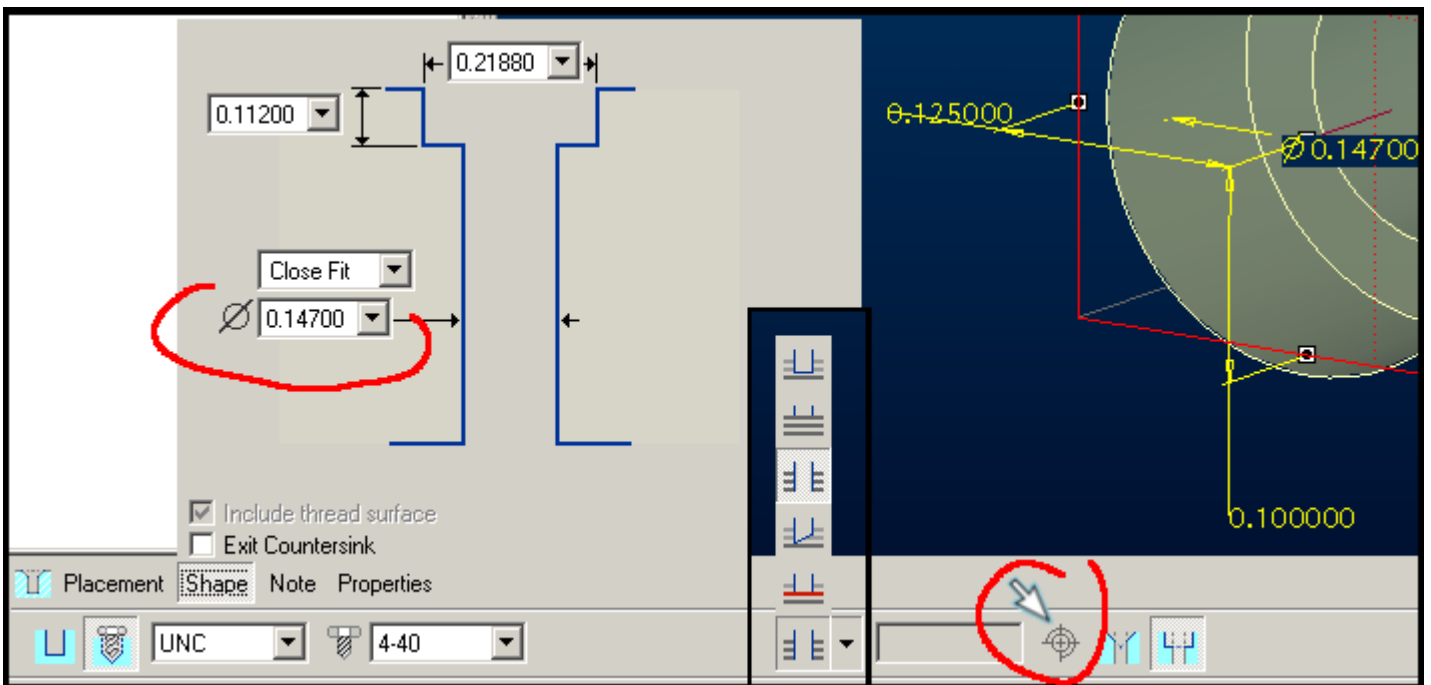

Insert -> Hole

Threaded hole icon, Thru all, and turn off the thread icon to switch it to a clearance hole

Set the CSink or CBores option

The Shape menu will provide a graphic for changing the size of the hole features

NOTE: In order to override the thru hole diameter, you must set the configuration option:  
 Tools -> Options -> HOLE\_DIAMETER\_OVERRIDE -> Yes

2 - Insert a Sketched hole

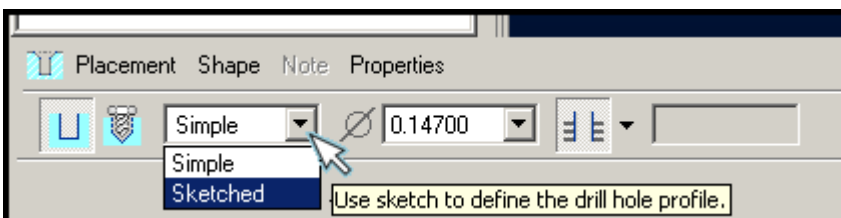

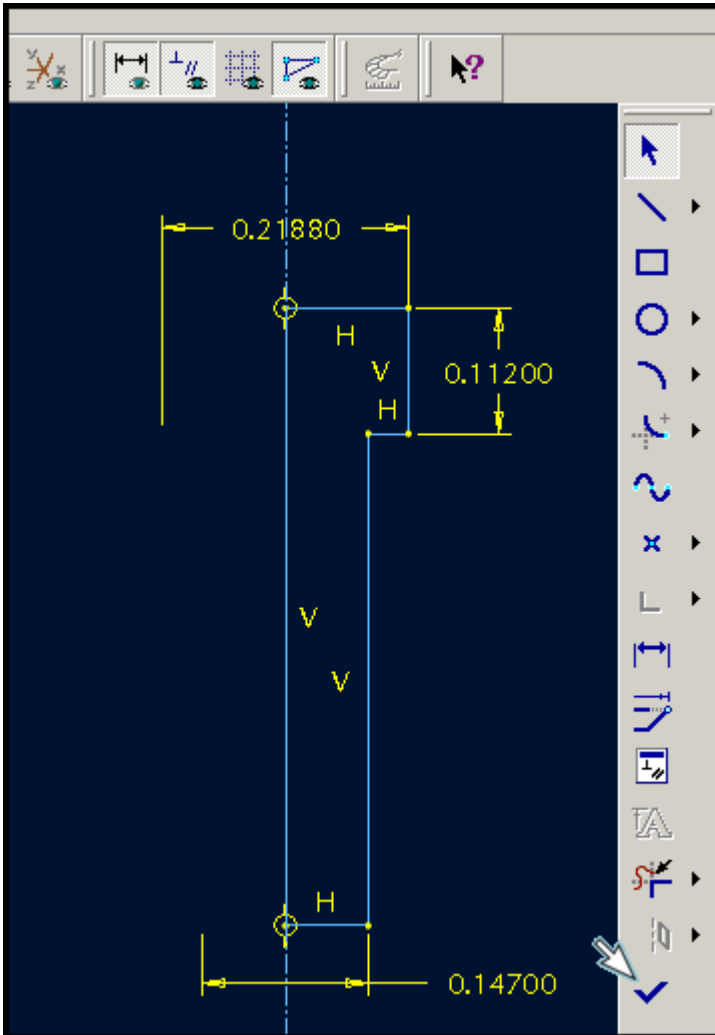
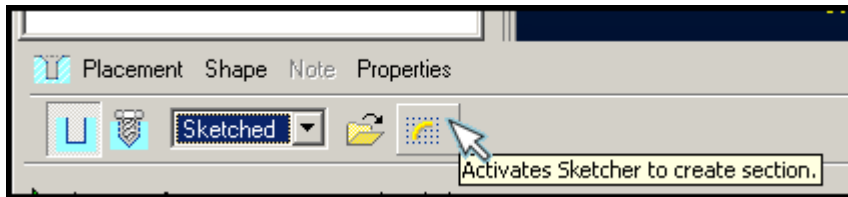

Insert a Center Line and sketch the desired hole shape and click the Continue Checkmark when done

